

PROGRAMMABLE RECORDERS WITH DIGITAL DISPLAY AND CONFIGURATION BOARD - REG3T



REG3T/6CH - 6-pen multipoint recorder

- 4-Colour digital display with analogue bargraphs
- Roll or Z-fold chart
- Front panel or PC configuration
- Universal isolated inputs
- Chart illumination
- Maths, timers, counters and totalisers
- Memory card (PCMCIA) reader
- MODBUS® communications
- 236 mm overall depth behind panel
- Up to 16 relay outputs
- Up to 4 analogue outputs
- 16 contact inputs

DESCRIPTION

The **REG3T** is a high specification multipoint chart recorder, capable of plotting up to six signals. Enclosed in a sheet steel case designed to meet the requirements of an industrial environment, the recorder is ideal for production or test environments.

DISPLAY

The display module for the REG3T is a high resolution four-colour vacuum fluorescent display (VFD) comprising five 12mm characters for process value, twenty 4mm characters for text and three 1mm bargraphs. The display shows the measured value of each channel in turn, together with its associated descriptor of scale. It also gives bargraphs indication of the channels values.

CONFIGURATION

The recorder is fully configurable from the front panel, using push-button keys to follow a series of text prompts. This allows access both to simple operator facilities and, via a password, to the more complex input and instrument configuration. The recorder can also be configured from a DOS based package, allowing the user to set up the configuration off-site for later downloading to the recorder.

INPUT TECHNOLOGY

Use of the very latest in Application Specific Integrated Circuit (ASIC) and Surface Mount technologies, gives the **REG3T** input circuitry high accuracy and stability. Inputs are fully universal accepting inputs from thermocouples, resistance thermometers and potentiometers.

CHART ILLUMINATION

This option provides a fluorescent tube above the chart, making the traces significantly more visible, even in well lighted areas.

MATHS, TIMERS, COUNTERS AND TOTALISERS

These options provide the recorder with integrating and counting facilities, and the ability to carry out calculations ranging from simple arithmetics functions (e.g. subtracting one channel's value from another) to complex application specific functions such as Relative Humidity calculations.

MEMORY CARD READER

Using the computer industry standard SRAM PC card type 2, the recorder's configuration can be stored for transfer to another recorder or to a PC for manipulation using the PC configuration tool. Data can also be stored on the memory card in a format readable by standard spreadsheet packages, or alternatively, in a format that allows it to be replayed to the chart to provide multiple copies.

MODBUS® COMMUNICATIONS

The communications option uses the MODBUS® RTU protocol to ensure compatibility with any standard SCADA software and other types of industrial equipment such as PLCs. The **REG3T** specification allows multiple instruments on a single communications link.

RELAY OUTPUTS

Up to 16 relay outputs can be fitted, driven by any internal recorder event such as channel alarm, totaliser overflow etc. Relays are available as changeover, or as common/normally closed or common/normally open.

RETRANSMISSION OUTPUTS

Up to four of the input or maths channels can be output as a linearised current or voltage signal.

CONTACT INPUTS

Recorder inputs can be used as digital inputs to trigger events. The Event input option adds the ability to read a further 16 (encoded) inputs.

DIMENSIONS in mm

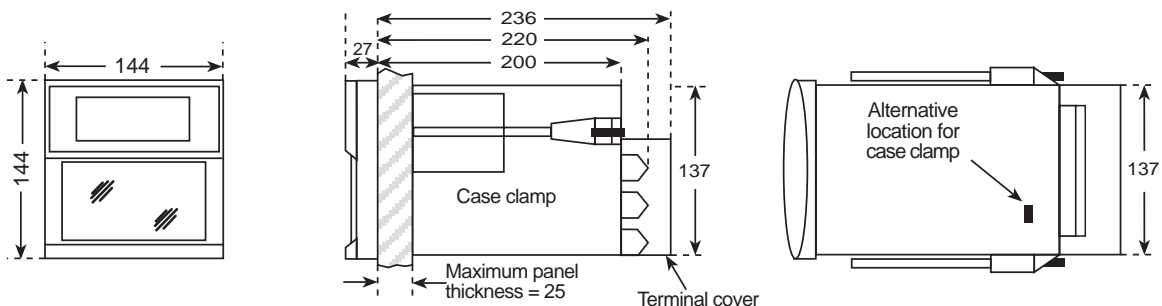

BOARD TYPES AND HARDWARE OPTIONS

- Standard Universal input / control board
- Options 3- Change-over relay output board
4 Normally open relay o/p board
4 Normally closed relay o/p board
Analogue output board (2 channel)
Event input board
Communications board
Transmitter power supply

PHYSICAL

- Panel mounting DIN 43700
- Bezel size 144 x 144 mm.
- Panel cutout dimensions 138 x 138 (both -0 +1 mm)
- Depth behind bezel rear face 220 mm (No terminal cover);
236 mm (with terminal cover)
- Weight < 3.5 kg
- Panel mounting Vertical ± 30°

ELECTROMAGNETIC COMPATIBILITY (EMC)

- Emissions BS EN50081-2
- Immunity BS EN50082-2
- Electrical safety To EN61010: Installation category II;
Pollution degree 2

PRINTING SYSTEM

- Pen type Six-nib cartridge
- Pen resolution 0.2 mm
- Trace colours See table 5
- Pritthead life 1.5 x 10⁶ dots per colour
- Update rate 2 Hz
- Print rate (max) 1 pass every 1.5 seconds
- Characters per line 42

Channel	Colour
1	violet
2	red
3	black
4	green
5	blue
6	brown

Table 5 - Trace colours

ENVIRONMENTAL PERFORMANCE

- Temperature limits Operation: 0 to 50°C
Storage: -20 to +70°C
- Humidity limits (non-condensing) Operation: 5% to 80% RH
Storage: 5% to 90% RH
- Protection Door and Bezel: IP54. Sleeve: IP20
Transmitter PSU rear cover: IP10
BS EN61010
- Shock
- Vibration 2g peak at 10 Hz to 150 Hz

POWER REQUIREMENTS

- Line voltage Standard: 90 to 264V at 45 to 65 Hz
Enhanced interrupt protection: 90 to 132V at 45 to 65 Hz
Low voltage option: 20 to 53V ac/dc
(ac frequency range: 45 to 400 Hz)
- Power (max) < 100 VA
- Fuse type None
- Interrupt protection 40 ms at 75% max. instrument load

PAPER TRANSPORT

- Type Stepper motor driving sprocket tube
- Chart speeds 0 to 1200 mm/hr; 0 to 47 in/hr
- Chart type Standard: 16- metre z-fold
Option: 32 - metre roll
- Transport accuracy 0.5 cm in 16 metres (approx 0.03%)

Range	Speed (mm/hr)					Annotation (if fitted) inhibited above 300 mm/h
	1	2	3	4	5	
1	Off	5	20	60	120	
2	Off	10	20	60	120	
3	Off	10	30	60	120	
4	Off	20	30	60	120	
5	Off	30	60	120	300	
6	Off	20	120	600	1200	
7	Off	20	300	1200	3600	
8	Off	20	3600	18000	36000	

Table 6 - Chart speed range

SERIAL COMMUNICATIONS

- Type RS 422/485 MODBUS®
- Insulation (dc to 65Hz; BS EN61010) Installation cat.II; Pollution degree 2
Terminals to ground 50V RMS/dc (double insulation)

MATHS PACK

- Number of derived channels 16
- Level 1 functions Off, constant, add, subtract, multiply, divide, modulus
- Level 2 functions (additional to level 1) See table 6

Channel ave	Rate-of-change	3rd order polynomial
DV group ave	Sample-and-hold	F0
Rolling Average	Channel minimum	Relative humidity
e ^x	DV group latching min.	Linear mass flow
log _n	DV group cont. min.	Square root mass flow
10 ^x	Channel maximum	Zirconia probe
log ₁₀	DV group latching max	High/low select
	DV group cont. max	Switch

Table 6 - Level 2 maths functions

EVENT INPUTS

- N° of inputs 6 discrete or 16 binary coded inputs
as configured + chart synch.
- Insulation (dc to 65Hz; BS EN61010) Installation cat.II; Pollution degree 2
Event input to ground: 100V RMS or dc (double insulation)
Chart drive to ground: 100V RMS or dc (double insulation)
Event input to chart drive: 100V RMS or dc (double insulation)
Event input to Event input: 0V
- Recognition Levels Low: -30 to +0,8
High: 2 to 30V
- Maximum frequency Events: 1Hz; Pulse counting: 6Hz
- Minimum pulse width 62.5 ms
- Chart synchronization Chart speed: Selected speed at 200 pulses/sec.
Maximum pulse rate: 220 pps
Duty cycle: 20 to 80%

CUSTOMER LINEARISATION TABLES

- N° of tables available One
- N° of point pairs 32

RELAY OUTPUTS

- Maximum switching power 500VA or 60W
- Maximum breaking current 2 Amps within above power ratings
- Maximum contact voltage 250V within above power ratings
- Insulation (dc to 65Hz; BS EN61010) Installation cat.II; Pollution degree 2
Contact to contact: 300V RMS or dc (double insulation)
Contact to ground: 300V RMS or dc (basic insulation)

ANALOGUE RETRANSMISSION OUTPUTS

- Output ranges (user configurable)
Voltage: 0 to 10V (Source 5mA max)
Current: 0 to 20mA (max load resistance: 1kΩ)
- Update rate 2Hz
- Step response (10% to 90%) 250msec
- Linearity 0.024% of hardware range
- Performance See table 7
- Insulation (dc to 65Hz; BS EN61010) Installation cat.II; Pollution degree 2
Channel to channel: 300V RMS or dc (double insulation)
Channel to ground: 300V RMS or dc (basic insulation)

Performance in instrument at deg.C		
Range	Accuracy	Temperature drift
0 to 10V	0,1% of range	+/- 1 µA + 0,03% of reading per deg.C
0 to 20mA	0,1% of range	+/- 0,1mV + 0,022% of reading per deg.C

Tabella 7 - Analogue output performance

TRANSMITTER POWER SUPPLY

- Output voltage 3 or 6 x 25V (nom) outputs
- Insulation (dc to 65Hz; BS EN61010) Installation cat.II; Pollution degree 2
Channel to channel: 100V RMS or dc (double insulation)
Channel to ground: 300V RMS or dc (basic insulation)

GENERALITY

<ul style="list-style-type: none"> ■ Input types ■ Input type mix ■ Maximum number of inputs ■ Input range ■ Termination ■ Noise rejection (48 to 62 Hz) 	dc Volts, dc millivolts, dc milliamps (with shunt), Thermocouple, 2/3 wire RTD (Channel 1 can be RTD only if no other channels are thermocouple) Contact closure (not ch.1) > 250ms Freely configurable 6 -8 to + 38 mV; -30 to + 150 mV; -0.2 to + 1 Volt; -2 to + 10 Volts Edge connector/terminal block Common mode: >140dB (channel to channel and channel to ground) Series mode: >60dB	<ul style="list-style-type: none"> ■ Maximum common mode voltage ■ Maximum series mode voltage ■ Insulation (dc to 65 Hz; BS EN 61010) ■ Dielectric strenght (BS EN61010) ■ Insulation resistance ■ Input impedance ■ Over voltage protection ■ Open circuit detection 	250 Volts continuos 45 mV at lowest range; 12 Volts peak at highest range. Installation cat. II; Pollution deg. 2 Channel to channel: 300V RMS or dc (double insulation) Channel to ground: 300V RMS or dc (basic insulation) (1 minute type tests) Channel to channel: 2300 Vac Channel to ground: 1350 Vac >10 MΩ at 500 V dc 38 mV, 150 mV and 1V ranges: >10MΩ; 10V range: 245 kΩ 50 Volts peak (150V with attenuator) ±57 nA max. Recognition time 500 msec. Minimum break resistance 10 MΩ
--	---	--	---

THERMOCOUPLE DATA

<ul style="list-style-type: none"> ■ Temperature scale ■ Bias current ■ Cold junction types ■ CJ error ■ CJ rejection ratio ■ Remote CJ ■ Upscale/downscale drive ■ Types and range 	ITS 90 0.05 nA Off, internal, external, remote 1°C max; instrument at 25°C 50:1 minimum Via any user defined channel High, low or none selectable for each thermocouple channel see table 2
---	--

T/C Type	Overall range (°C)	Standard	Max linearisation error
B	0 to + 1820	IEC 584.1	0 to 400°C: 1.7°C 400 to 1820°C: 0.03°C
C	0 to + 2300	Hoskins	0.12°C
D	0 to + 2495	Hoskins	0.08°C
E	-270 to + 1000	IEC 584.1	0.03°C
G2	0 to + 2315	Hoskins	0.07°C
J	-210 to + 1200	IEC 584.1	0.02°C
K	-270 to + 1372	IEC 584.1	0.04°C
L	- 200 to + 900	DIN43700:1985 (da IPTS68)	0.20°C
N	-270 to + 1300	IEC 584.1	0.04°C
R	- 50 to + 1768	IEC 584.1	0.04°C
S	-50 to + 1768	IEC 584.1	0.04°C
T	- 270 to + 400	IEC 584.1	0.02°C
U	-200 to + 600	DIN43710:1985	0.08°C
Ni/NiMo	0 to + 1406	Ipsen	0.14°C
Platinel	0 to + 1370	Engelhard	0.02°C

Table 2 - Thermocouples types and ranges

DC INPUT RANGES

<ul style="list-style-type: none"> ■ Shunt/attenuator ■ Additional error due to shunt ■ Additional error due to attenuator ■ Typical Performance 	externally mounted resistor modules 0.1% of input 0.2% of input See table 1
--	--

Low Range	High Range	Resolution	Maximum error (instrument at 20 °C)	Worst case temperature performance
-8 mV	38 mV	1.4 μV	0.08% input + 0.06% range	80 ppm of input per deg C
-30 mV	150 mV	5.5 μV	0.08% input + 0.04% range	80 ppm of input per deg C
-0.2 Volt	1 Volt	37 μV	0.08% input + 0.05% range	80 ppm of input per deg C
-2 Volts	10 Volts	370 μV	0.155% input + 0.04% range	155 pmm of input per deg C

Table 1 - DC performance

RESISTANCE INPUTS

<ul style="list-style-type: none"> ■ Ranges (including lead resistance) ■ Influence of lead resistance ■ Temperature scale ■ Resolution and performance ■ RTD types and ranges 	0 to 150 Ω, 0 to 600 Ω, 0 to 6 kΩ Error: negligible Mismatch: 1Ω/Ω ITS90 See table 3 See table 4
---	---

Low Range	High Range	Resolution	Maximum error (instrument at 20 °C)	Worst case temperature performance
0Ω	150Ω	5mΩ	0.04% input + 0.033% range	35 ppm of input per deg C
0Ω	600Ω	22mΩ	0.04% input + 0.032% range	35 ppm of input per deg C
0Ω	6kΩ	148mΩ	0.04% input + 0.029% range	35 ppm of input per deg C

Table 3 - Resistance ranges resolution and accuracy

RTD types	Overall range (°C)	Standard	Max linearisation error
Cu10	-20 to + 400	General Electric Co.	0.02°C
JPT100	-220 to + 630	JIS C1604:1989	0.01°C
Ni100	-60 to + 250	DIN43760:1987	0.01°C
Ni120	-50 to + 170	DIN43760:1987	0.01°C
Pt100	-200 to + 850	IEC751	0.01°C
Pt100A	-200 to + 600	Eurotherm Recorders SA	0.09°C
Pt1000	-200 to + 850	IEC751	0.01°C

Table 4 - RTD types, ranges and accuracies

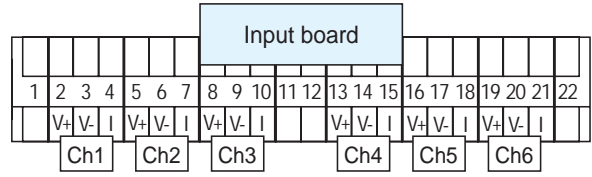
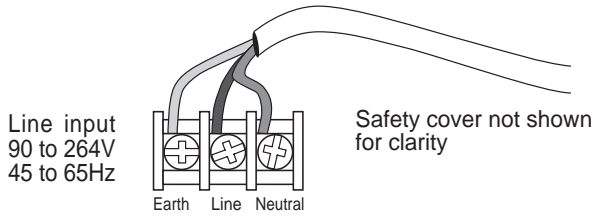

INPUT BOARD SIGNAL WIRING

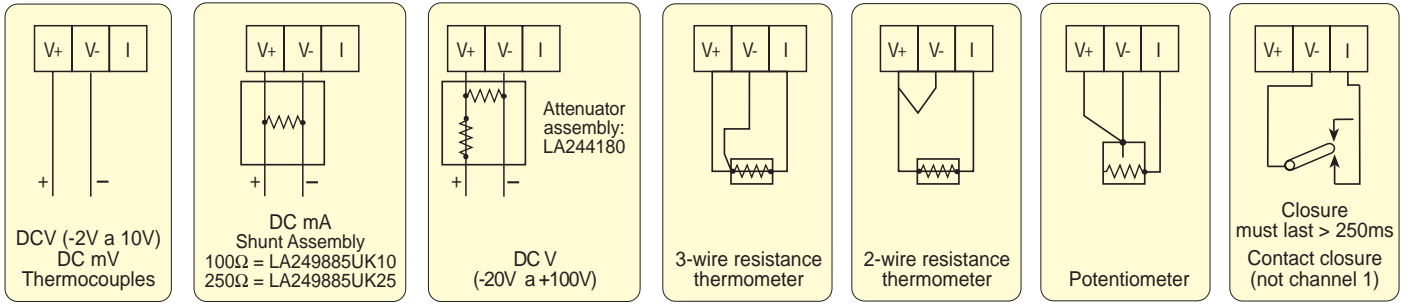

OPTION WIRING

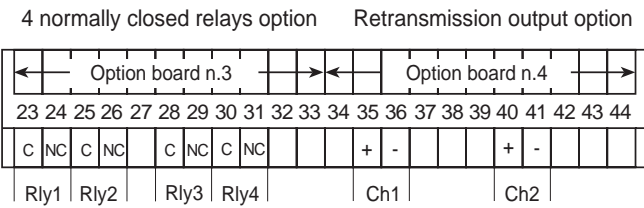
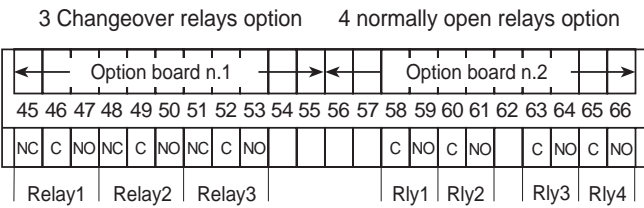

Relays and retransmission termination

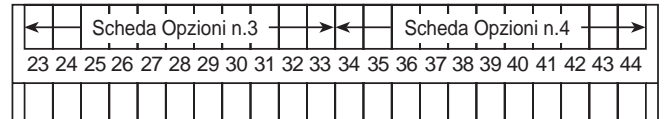
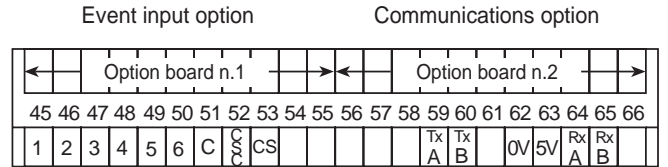

Event input and serial communications termination